

**AMBA TEX**  
ENGINEERS

# Our Product Range

- 01 Fabric Brush/Sueding Machine**
- 02 Peach Finish Machine**
- 03 Dust Cleaning Machine**
- 04 Fabric Inspection Machine**
- 05 Fabric Roll Opening Machine**
- 06 Fabric Batching Machine**
- 07 Fabric Inspection Machines (Combinations)**
- 08 Fabric Roll Wrapping Machine**
- 09 Stenter Machine Parts**
- 10 Fabric Selvedge Shifting Unit**
- 11 Stenter Fabric Gumming Device**

# Fabric Brush/Sueding Machine

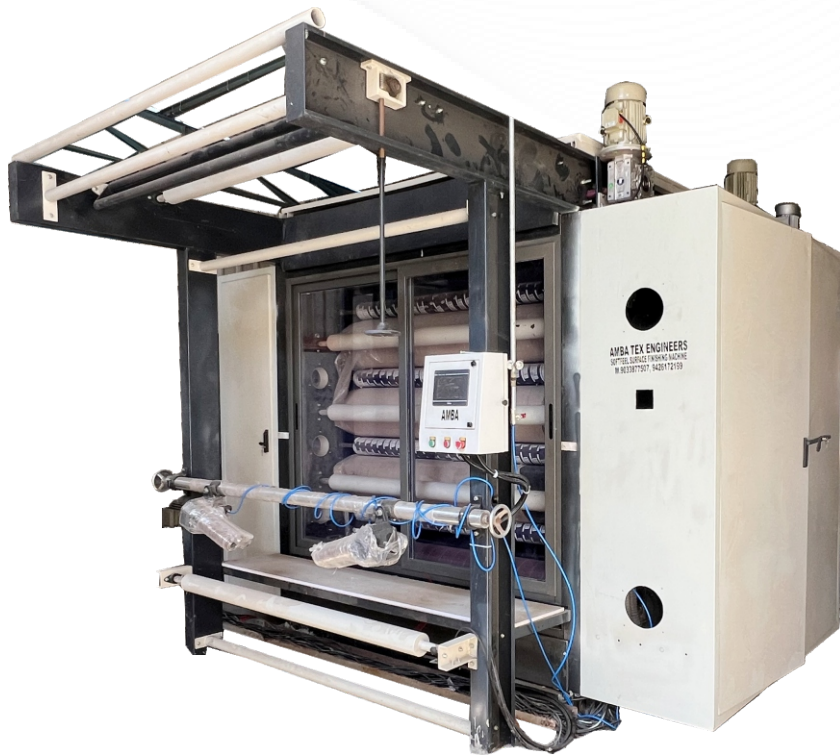

- The New Softfeel machine, is characterized by its high brushing efficiency due to the considerable number of contact points.
- Special holes in different places on the machine's frame, let's the suction working in transversal way, that means that the air is sucked up from one side of the machine, acrossing the entire machine collecting all the dust from the brushing sueding process.
- This system assure a perfect cleaning from the machine.
- On the machine, can be installed Abrasive brushes (CARBON OR CERAMIC) or Sueding rollers for excellent sueding.

## FEATURES :

- Abrasive brushes: Available in CARBON & CERAMIC these brushes give a softer-effect and a more delicate peaching look.
- Emery: Normal emery removes a layer of fabric, attaching all those fibres present at the same level, it is used for heavier peach effect.

## ADVANTAGES :

- High productivity due to more efficient use of the brushes or of the diamond emery rollers.
- High quality as a result of constant control of the fabric tension in every point of the machine.
- Possibility to process both faces of the fabric in one passage of the fabric from the machine.
- Simple operation One single machine, instead of two different machines. (For Two Side).
- High efficiency.

## One side 4 Rolls

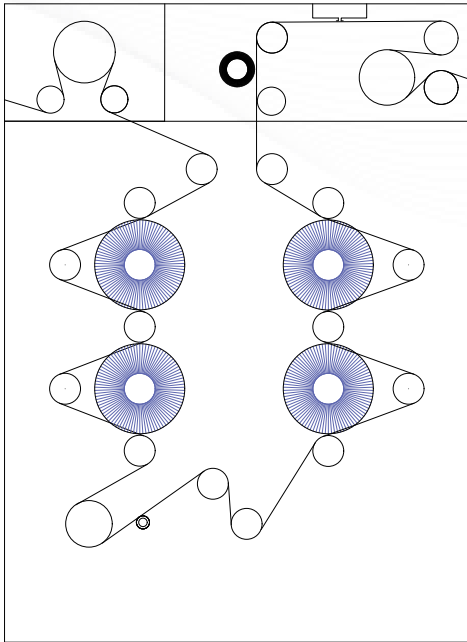

## Two side 6 Rolls

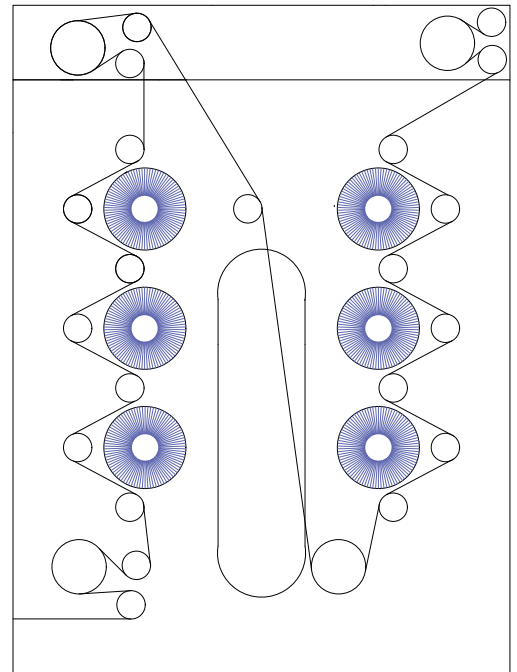

Table Width	FROM 1600 mm TO 3600 mm
Working Width	FROM 1400 mm To 3400 mm
Machine Speed	0-40 MTRS/MIN (Depending on Type Fabric)
Installed Power	60 - 80 KW
Abrasive Diameter	300 mm, 320 mm, 340 mm
Sueding Roll Diameter	160 mm to 200 mm

**The exposed features are indicative and could be changed at any time.**

# Peach Finish Machine



- Designed for Cotton, Synthetic & Blended fabric (also available in 2 side to impart soft finish like peach skin effect on one/two side of fabric.
- The fabric gives comfortable feel and so this machine offers value addition.

## FABRIC TREATMENT

- One side / Two side.
- No. of sueding pneumatics cylinders - 5 (for one side).
- Length / width / height - 5000/3000/3300 mm. (1600 working width)

Table Width	FROM 1600 mm To 3600 mm
Working Width	FROM 1400 mm To 3400 mm
Machine Speed	0-25 MTRS/MIN (Depends on Fabric )
Installed Power	30 - 40 KW
Emery Roll Diameter	165 mm - 219 mm

**The exposed features are indicative and could be changed at any time.**

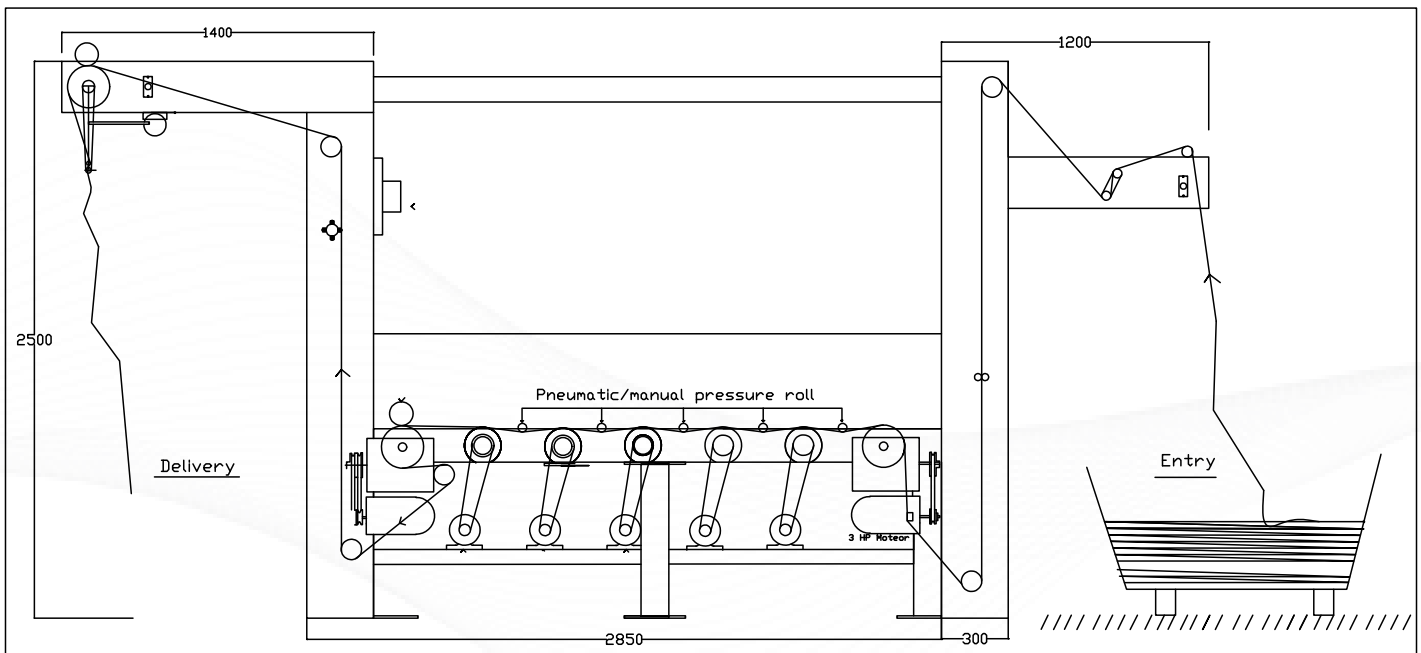

## Dust Cleaning Machine

- This Brushing / Cleaning Machines is an efficient group easily applicable in front of any machine or stand alone.
- Brushes are working at the same time on the front and on the back of the fabric to assure the maximum efficiency.
- This Brushing/Cleaning Machines is a COMBINATION of three actions:Beating / Brushing / Sucking.
- Beating is made by beaters rollers and brush by the means of brush rollers, sucking is made from an efficient Air Sucking System that catch the removed dust / lint and collect them to an external filter unit.
- Brushes and beaters rollers are working at the same time on front and on back side of the fabric to assure the maximum cleaning efficiency.
- The entire unit is made of mild-steel.
- High power Brushing machines suitable for all fabric cleaning operations, where traditional brushes can not obtain positive effects.
- Comes with high efficiency blower for powerful suction.
- Available in working width from 1400 mm to 3400 mm.

**Model Amba D-1**

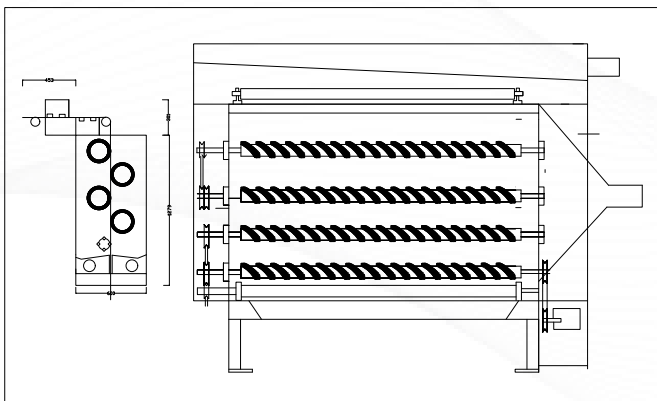

**Model Amba D-2**

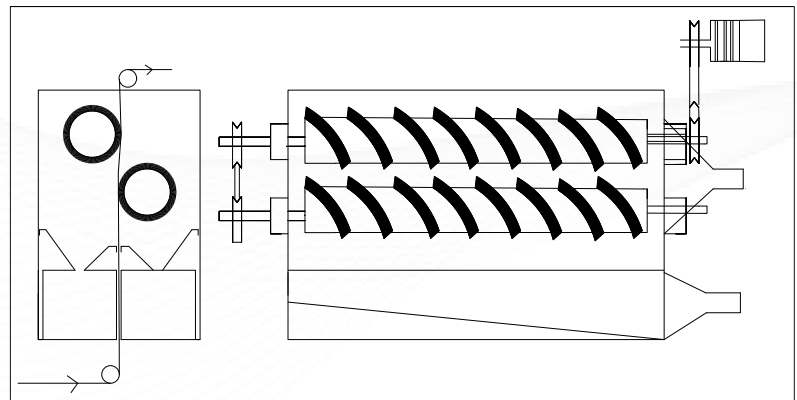

# Fabric Inspection Machine

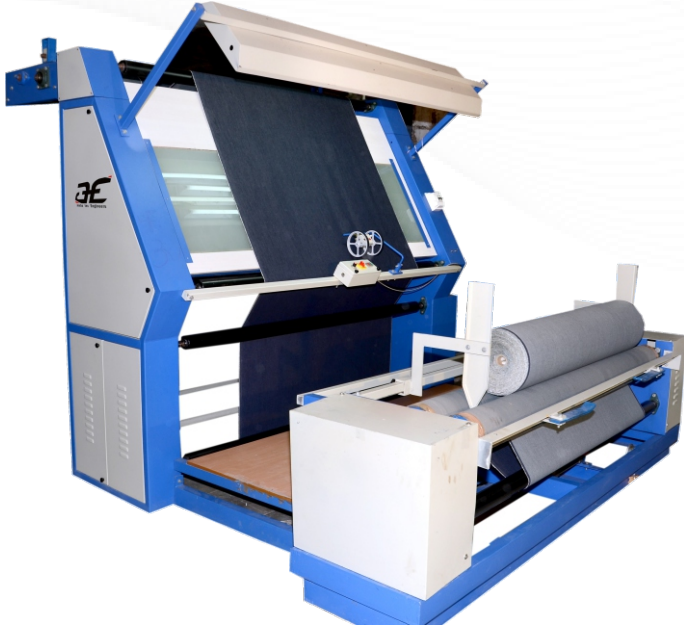

## Features :

- Working speed variable 0 - 50 mtrs/min.
- Mild steel construction with tie-bars guide roller deposit board inclined inspection table for comfortable Inspection.
- Mechanical counter meter, reversible for full length, various fabric input & output options.
- Start, Stop, and Reverse function.
- Wooden board with white covering Acrylic sheet of inspection table width and tube light cloth measuring by precise Mechanical counter meter.
- Fabric is controlled by bow pipe.

## TECHNICAL SPECIFICATIONS

- Fabric Feeding system from loose or Roll of maximum 500 mm.
- Fabric winding truck at the back of the operator.
- Min width 1000 mm.
- Max. width 3400 mm.
- Max. Dia. of the inspected roll 500 mm.
- Inspected roll weight 80 to 100 kgs.
- Start, stop push button on front side.
- Speed control with inverter Delta make.
- Hydraulic power pack for Edge Guiding System.

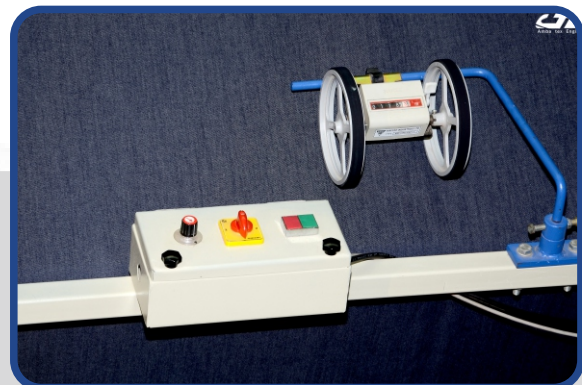
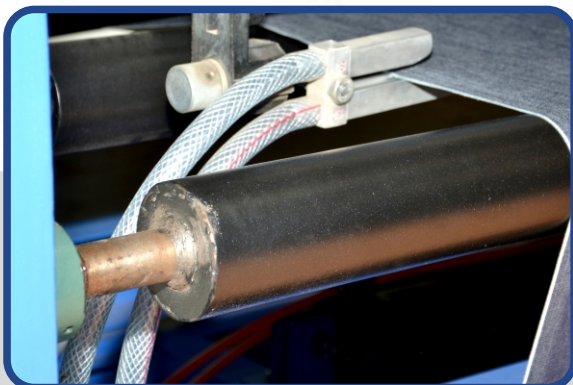

## Fabric Roll Opening Machine

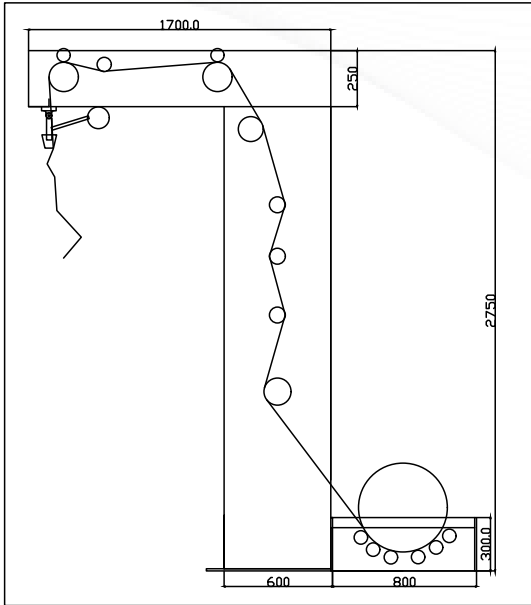

### GENERAL FEATURES:

- Machine speed will be 0-50 mtrs/min fabricated structure.
- The machine will be of 1600 mm - 3400 mm roller face suitable for fabric up to 3200 mm fabric width.
- The structure will be fabricated form of 3-5 mm thickness M.S plate. also includes M.S guide roll (powder coated), tension unit and necessary tie bars with plaiting device.
- The drive includes 2 HP geared motor with suitable control panel. the geared motor will be of "Euro make " and inverter will be of " Delta make.

## Fabric Batching Machine

### GENERAL FEATURES:

- Made from fabricated structure.
- Expander type bow pipe.
- 24"x 3" pneumatic cylinder.
- Tie rods as required.
- M.S. roll as required, tension unit 1- set.
- Entry 1 HP and delivery 2 HP A.C. geared motor (Euro make).
- Invertor will be of Delta machine.
- Machine speed will be 0 to 50 mtrs / min.

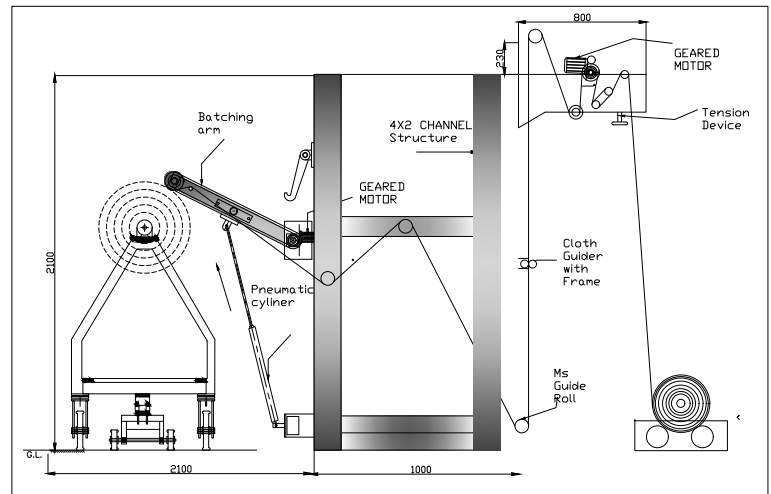

# Fabric Inspection with opening/ batching / Tube Rolling

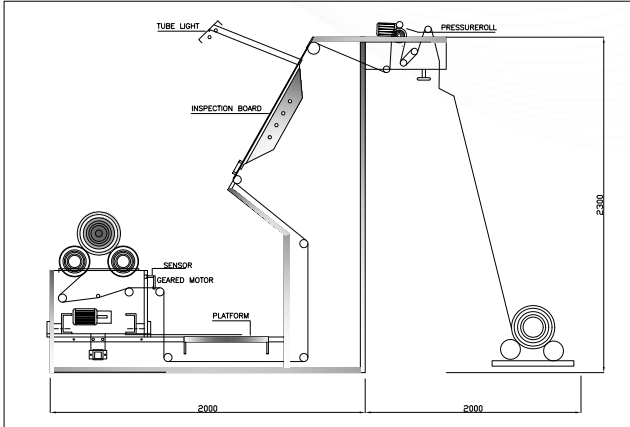

**Amba Model FI - 01**

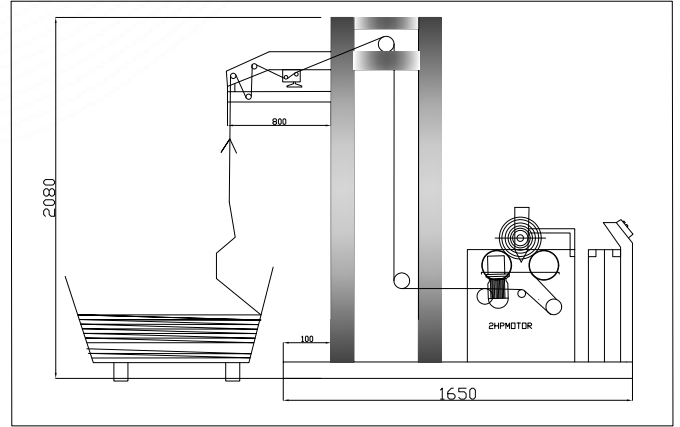

**Amba Model FI - 02**

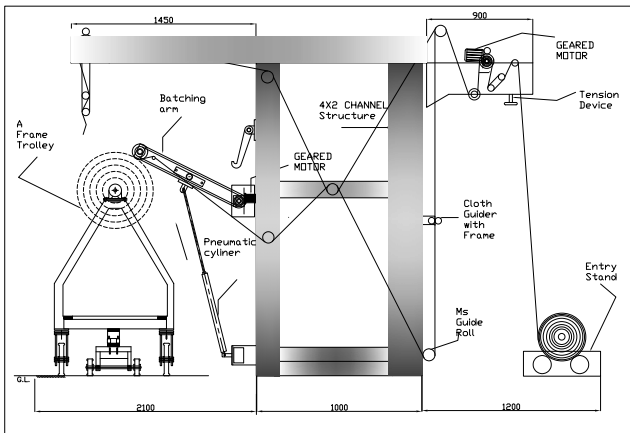

**Amba Model FI - 03**

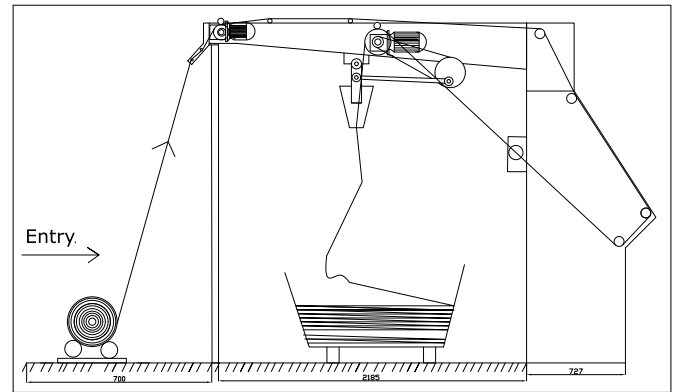

**Amba Model FI - 04**

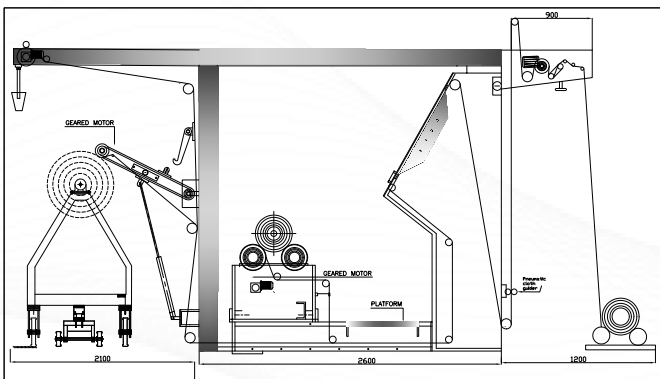

**Amba Model FI - 05**

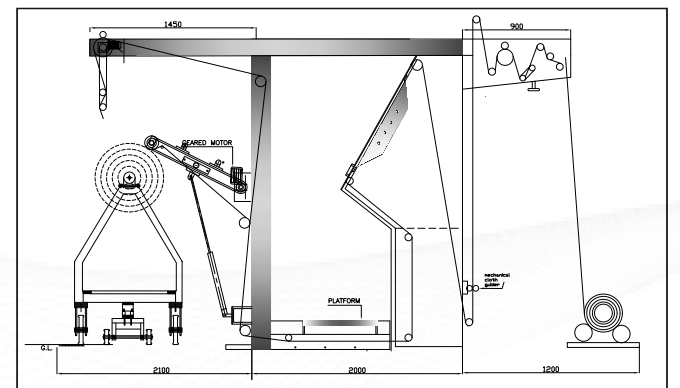

**Amba Model FI - 06**

## Fabric Roll Wrapping Machine

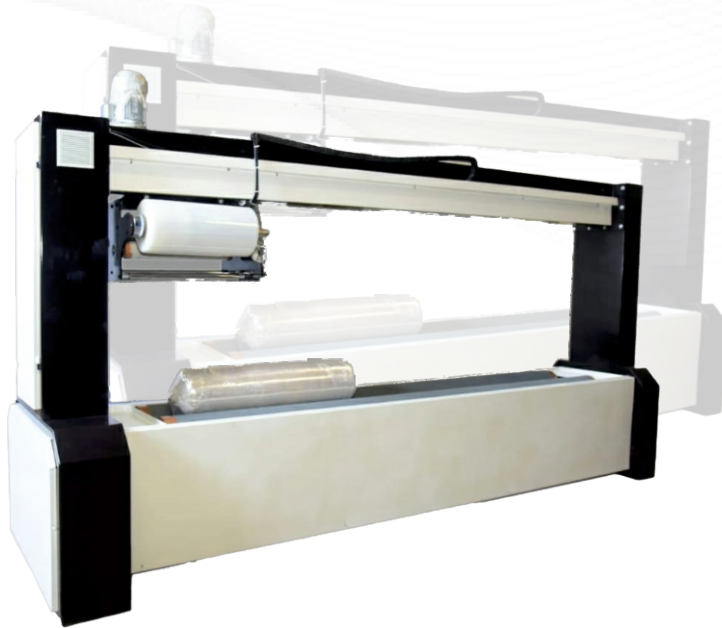

- The Stretch Wrapping Machine is designed for wrapping fabric rolls with power pre-stretch film carrier, it requires minimum film consumption that allows you to reduce packing cost, the robust packing protects the fabric roll with any damage, moisture or dust.

### Features :

- Roll wrapping with stretch film programmable film tension, variable number of cycles programmable head speed PLC control.

Working width From 1800 mm - 3400 mm suitable for any kind of fabric roll.

- Suitable for maximum dia of fabric roll 600 mm.
- Fully Automatic machine with three inverter driven for 1 HP, 0.5 HP, 0.5 HP Motor with Gear Box Euro Make.
- HMI Delta Make CG make Drives film stretching (29 micron) approx 300%.
- Machine stops automatically after completion of 1 roll wrapping, variable setting of number of rounds per fabric roll on both end.

## Stenter Machine Parts



**3 Finger Uncurler**



**2 Finger Uncurler**

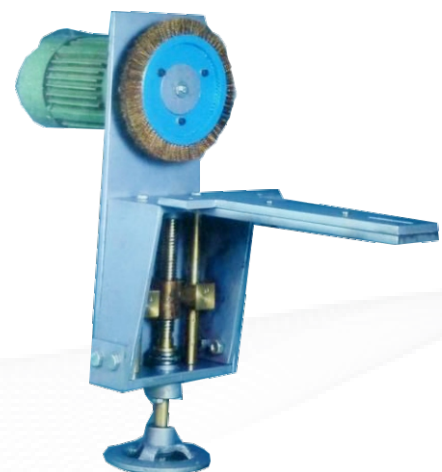

**Pin Bar Cleaner**

## Fabric Selvedge Shifting Unit

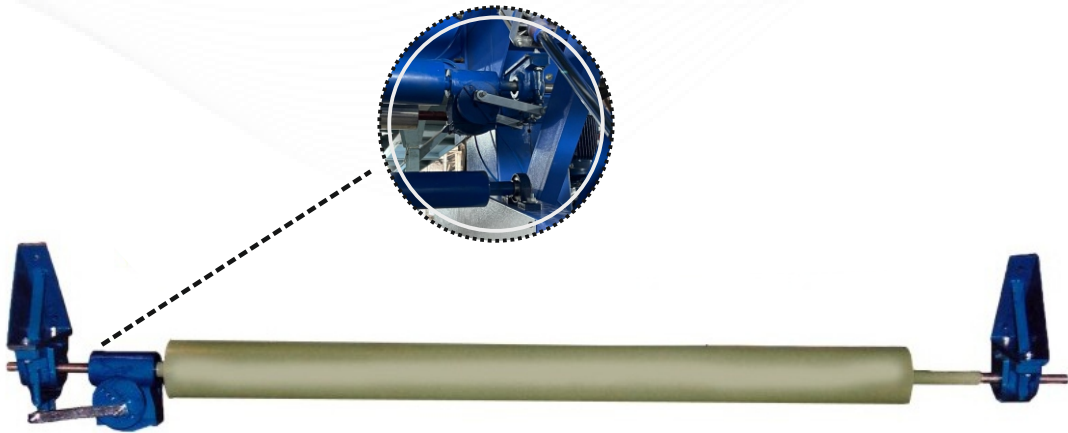

- Working width 1600mm-3000mm, this device is Used Mostly In Stenter Machine before batching.
- Imported Type Selvedge shifting device is arranged using positively given M.S. Roller.
- Supported on SP. type Bearing, Pedestal with Metal Bush.
- M.S. structure, With SP. type worm & worm wheel gearbox.

## Stenter Fabric Gumming Device



- Gumming device can easily fit on any indian make machines.
- Nylon wheels on both the side.
- Tray is of Stainless Steel.
- Tap system for collecting the gum.
- Adjustable mountings through feeding system.

## OUR CLIENTS



**AMBA TEX**  
ENGINEERS

📍 39/40, Shankar Estate, Near Revabhai Estate, Ctm, Ahmedabad -380026

☎ 9033877507 , 9426172199

✉ ambatexeng@gmail.com / amba\_texeng@yahoo.com

🌐 www.ambatexengineers.com